

NEWSLETTER

Volume 4, No. 2

September, 1999

September Meeting --

Anvil Repair Workshop

The anvil-repair workshop will be hosted by the **Orange County Farmers Museum** on **Saturday and Sunday, September 25-26**. For \$100 and some sweat labor you get your beat-up old anvil repaired with freshly welded, ground and polished edges and face. Anvils missing chunks of the face can also be repaired, but may require more preparation, labor, and possibly money on your part. **This is a two-day workshop -- welding on the first day and grinding and polishing on the second. Lunch will be provided. Please bring an item for the iron-in-the-hat. As usual, tailgaters are welcome.**

For further information, contact Greg Phillips 914-457-5671 suresign@frontiernet.net. (If you can't get through to Greg, you may contact David Macauley, 732-206-1568 or 732-949-8422 drm@anchor.ho.att.com)

Directions to Orange County Farmers Museum: Take the Garden State Parkway north into New York State. Pick up the NYS Thruway (Route 87), and take it north to exit 17 (Newburgh- Stewart Airport) after exiting and the toll booth DO NOT bear right onto Route 84, continue straight to traffic light at Route 17k. Turn right (west) onto Route 17k proceed 6.2 miles to Berea Road on the right. Take Berea Road 500 feet to Orange County Farmers Museum entrance on right. Between two brick pillars. (There is no phone at the museum.) Carpooling from New Jersey: Contact David Macauley or Marshall Bienstock (see "NJBA Directors").

October Meeting

The October membership meeting will be held on **Sunday, October 24, at the forge of Dan Cruzan near Bridgeton, NJ.** (If you'd like give a demonstration, contact NJBA Director Steve Rhoades.) The tentative schedule for the meeting is as follows:

9:30 a.m.	- arrival, coffee, socializing
10:00 a.m.	- demonstrations begin.
12:00 p.m.	- lunch, socializing, tailgate sales, IITH
1:30 p.m.	- demonstration resume.

Lunch will be provided. Please bring a project you have made that to inspire us all. **Bring lawn chair** (and extra chairs if you can). Please bring something to donate to the **iron-in-the-hat**. And bring all your old surplus tools, supplies, books or whatever for the **tailgate sale**.

Dan's forge is near Bridgeton (Cumberland Co. NJ). **If coming southbound on the NJ turnpike**, get off at exit 2. Take Rte. 322 east to Mullica Hill. Take Rte. 77 south about

six miles to Deerfield, which is at the intersection of Rtes. 77 and 540. From Deerfield, proceed west on route 540. Go past the 20 mile marker and at the next intersection turn left onto Harmony Rd. Go to the stop sign turn left onto Walters Rd. Go 200 yards and turn right onto Harmony Rd. Dan Cruzan's-Nursery is the first farm on the right (146 Harmony Rd., Bridgeton, NJ, 08302.

609-451-0904). **If coming into NJ across Delaware Memorial Bridge** take Rte. 49 east, (pick up 49 at the foot of the bridge). Go past the 19 mile marker on Rte. 49, turn left onto Jericho road. At the next stop sign go straight across onto Moore's Corner Road. At the next stop sign turn left onto Harmony Road. Dan's is the first farm on the left.

Persons interested in **carpooling** should contact NJBA Director Bruce Freeman.

November Meeting

No announcement was submitted to the editor. Plans were to hold the meeting at Peters Valley, on a weekend early enough in the month to avoid the Thanksgiving weekend.

December Holiday Party

No announcement was submitted to the editor. Plans were to hold the party at Longstreet Farm, on a weekend early enough in the month to avoid the holidays.

Monday Night Open Forge

We encourage any NJBA to join us at Marshall Bienstock's shop for the weekly open forge meeting at 7 pm almost every Monday evening. (Please call ahead on holiday weekends to make sure the shop will be open. 732-780-0871.) This is a great venue for beginners, but all are welcome.

NJBA at the Monmouth Co. Fair

The NJBA participated in the Monmouth County Fair, in conjunction with the Longstreet Farm Exhibit, July 21 - 25. David Macauley headed up the effort, with Marshall Bienstock and others participating. (Unfortunately, no one submitted a report, so details are lacking.)

Report on the Hood Workshop

On August 14, the NJBA held a very successful Forge Hood Workshop. The event was held at Marshall Bienstock's shop in Howell NJ. Several members had expressed a desire to make these for their own shops, so we organized the workshop. We also planned to make hoods for Peters Valley and Longstreet Farm. The weather was hot and humid and at the end of the day we were

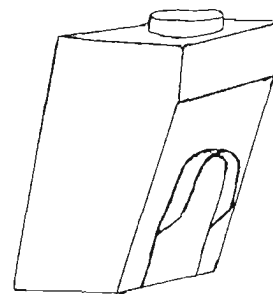

New Jersey Blacksmiths Association

all drenched with sweat, but we had accomplished what we had planned to do. We had good attendance from the members who didn't want to purchase the hoods, but wanted to come and help with the workshop and I would like to thank them all for their efforts. I would like to thank every one their for their help making this workshop a success, especially Marshall for his help in setting this up, the use of his shop and his time. The participants were David Macauley, Ron Jani, Jim Helstrom, Greg Phillips, John Chodrba, Dan Cruzan, Peter Bazakas, Tom Gambino, Ben Suhaka, Josh Kavett, Frank Decicco, Tom Glynn, Paul Norris, Marshall Bienstock, Jeff Morelli and Bruce Freeman.

Thanks to all, Larry Brown

Several hoods are still available, but the board has not yet set the price. If interested contact ; Larry Brown (718) 967-4776 lnbrown@con2.com or Dave Macauley(732) 206-1568 drmacauley@att.com - Larry Brown

Events Elsewhere

October 17, 1999. Hammer-A-Thon '99 at the Mountain Village Blacksmith Shop. The expansion is complete (or will be by that date), and the traditional christening of the forge will done. The demonstrators are Walt Scadden and Michael Sarri. Both of these gentlemen are outstanding blacksmiths. Walt's demo is going to focused on scrolls and architectural ironwork. Everyone who pre-registers for the hammer-in will receive a Hammer-A-Thon '99 tee-shirt. The lunch is provided, a buffet that will put last years to shame. The Iron-In-The-Hat table will be stacked with some interesting objects. Lastly, there is plenty of room to tail-gate and tables to show off your prize works. For further information, contact Keith Foster 141 Moxley Road, Uncasville, CT 06382

Blacksmithing Workshops in MD

Academy of Traditional Arts
at the Carroll County Farm Museum
500 South Center Street, Westminster, MD 21157
(410) 848-7775, (410) 876-2667

Classes are \$100 per person. Call for further information.
Nov 2 & 9 Blacksmithing Christmas Items Bob Morris

Blacksmithing Workshops in PA

Touchstone Center for Crafts
R.D. #1, Box 60, Farmington, PA 15437
Ph: (724) 329-1370; FAX: (724) 329-1371;
Email: tcc@hhs.net; Internet: www.touchstonecrafts.com
(Abbrev: "B" = beginner, "I" = intermediate, "A" = advanced.)

Date	Instructor	Class Description	Level
Sep 10-12	Ray Rybar	"Basics of Damascus Knifemaking"	B
Sep 17-19	Ivan Bailey	"Hand-Forged Small Animals"	I-A
Sep 24-26	Jymm Hoffman	"18th C. Camping Equipment"	I
Oct 1-3	Hans Peot	"Tools from Scrap Steel for Beginners"	B-A
Oct 8-10	Jody Best	"Blacksmithing for the Completely Ignorant but Eager to Learn"	B-A
Oct 15-17	Glenn Horr	"Using a Hand-Held Air Hammer"	I-A

NJBA Board of Directors

Marshall Bienstock, Director until June, 2001
663 Casino Dr., Howell, NJ 07731
732-938-6577 732-780-0871
mbienstock@worldnet.att.net

Larry Brown, Director until June, 2001
90 William Ave., Staten Island, NY 10308
718-967-4776

lnbrown@con2.com, brownln@hotmail.com

Bruce Freeman, Director until June, 2000
222 Laurel Place, Neptune, NJ 07753
732-922-8408, 609-716-2827

freeman@monmouth.com, freemanb@pt.cyanamid.com

Jon Folk, Director until June, 2001
P.O.Box 143, Old Bethpage, NY 11804
516-474-3109, rn425268@nassaulibrary.org

Bill Gerhauer, Director until June, 2000
415 Hutchinson St., Hamilton, NJ 08610
609-394-1817, bgahow@earthlink.net

Josh Kavett, Director until June, 2001
471 Casino Dr., Farmingdale, NJ 07727
732-431-2152, jakavett@aol.com

Bill Ker, Director until June, 2001
Box 14, Allenwood, NJ 08720
732-223-4188, KemoKimo@aol.com

Doug Learn, Director until June, 2001
121 Pebble Woods Drive, Doylestown, PA, 18901
215-489-1742., doug.learn@Primedica.com

David Macauley, Director until June, 2000
4 Patricia Ct., Howell, NJ 07731
732-206-1568, 732-949-8422
drm@anchor.ho.att.com

Jeff Morelli, Director until June 2001
234 Rahilly Road, Wrightstown, NJ 08562
609-723-5990

Nate Pettengill, Director until June, 2001
24 Byron Rd., Short Hills, NJ 07078
npetteng@motown.lmco.com

Steven W. Rhoades, Director until June, 2001
513 Harding Highway, Vineland, NJ 08360
856-697-4144, hotiron1@juno.com

Bruce Ringier, Director until June, 2001
201-652-4526

Tim Suter, Director until June, 2000
1112 Ladner Ave., Gibbstown, NJ 08027
856-423-4417

Andy Vida-Szucs, Director until June, 2001
13 Old Monmouth Rd., Freehold, NJ 07728
732-308-9039, 732-957-6043
osan@netlabs.net

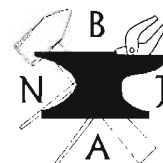

Editorial: My Resignation

It is with mixed emotions that I resign as NJBA newsletter editor. I have now been editor since the founding of NJBA, three-and-a-half years, and I feel that it's time for me to relinquish the position. I had wanted to relinquish the position at the end of three years, but decided to retain the position an additional year because there was no candidate in sight to assume it. However, due to recent aspersions concerning my performance as editor, I feel I have no choice but to resign effective immediately. - Bruce Freeman

New Editor Needed

The NJBA Board of Directors is seeking an editor or co-editors for to assume responsibility for publishing this newsletter. All NJBA members are encouraged to consider applying.

Responsibilities. It is the responsibility of the editor(s) to publish, at least quarterly, a newsletter which includes all available announcements of upcoming meeting, and any suitable materials submitted by the NJBA Board or by NJBA members. It is desirable that the editor utilize electronic mail and subscribe to the ABANA newsgroup, theForge, but these are not requirements for the post.

Division of Responsibilities. The duties of the editor may be divided between two or more persons. Currently, assistant editor Tim Suter receives newsletters from other ABANA chapters and peruses them for useful material for paste-up in the NJBA Newsletter; he can continue in this role.

Ancillary Responsibilities. In addition to preparing a "photo-ready" master copy of the newsletter for printing, the outgoing editor (1) had the newsletter printed and stapled, (2) maintained the NJBA roster and a separate list of ABANA chapter editors, (3) printed address labels for newsletter and other mailings, (4) purchased stamps, and (5) conducted the newsletter mailings, with the assistance of volunteers at the Monday evening open forge meeting. If the new editor cannot assume one or more of these ancillary responsibilities, he should call it to the board's attention when applying so that alternative arrangements can be made.

Format. The appearance and format of the newsletter is subject to the discretion of the editor and need not resemble the current format. The method the new editor chooses to assemble the newsletter is also at his discretion, and may, for example, be by modern computerized word processor, by traditional cut-and-paste, or by simple assembly of several submitted pages.

Financial. This is an uncompensated position. The outgoing editor assumed all up-front expenses of producing, printing and mailing each newsletter (about \$400 for the last issue), and was reimbursed by check for these expenses within a month. If any applicant for this position deems this arrangement unsuitable to their circumstances, he should call it to the board's attention when applying so that alternative arrangements can be negotiated.

The Scrap Corner

(A place of repose for bits and pieces that may someday be of use.)

Q: How can I punch small holes in a broken band saw blade to make it into hacksaw blades as I've been led to believe that it will make a superior hacksaw blade? And what's the best way to cut it into lengths?

A: Put a 16d nail in a drill press, head down. Mark the blade in two places, 12" apart and lower the nail head on the spot. hold it there until the smoke rolls or the nail turns blue or just about anything that says "hot." Same thing on second spot. You have now "spot annealed" the blade. The two points are soft enough to drill; the rest of the blade has not been affected. - Jack Yates

Letters to the Editor

Dear Editor,

Thanks to all those who made this (and all the other) newsletters happen. This last one in particular, Vol. 4 No. 1, seemed to have it all: valuable how-to info., scheduling, and interesting reading. I was very glad to see the Tempil chart. I had been referring to a raggedy old one downloaded off the web page. I was wondering what all that fine print said. I'm sure that it takes a considerable amount of time and effort to assemble and produce a newsletter with all this going for it. Thanks again.

-- Greg Phillips, Montgomery, NY



Rates for Photocopy-Ready Advertisements

Photocopy-ready advertisements must not contain photographs, solid black backgrounds, etc., and NJBA cannot be responsible if submitted copy does not reproduce well when photocopied. Send all copy to Bruce Freeman. (See NJBA Directors List.)

Size	Measurements (W x H, less margins)	Price
full page	7" x 9"	\$50
half page, vertical	3.4" 9"	30
half page, horizontal	7" x 4.4"	30
quarter page	3.4" x 4.4"	20
business card	3.3" x 2" overall	10
bus. card (NJBA members)	"	5

Rate for Unclassified Advertisements

Unclassified advertisements must be legible, preferably typed, double-spaced, text only. Electronic copy is appreciated.

Type and Size of Ad	Price
12 lines (about 100 words)	\$15
6 lines (about 50 words)	10
NJBA members, 12 lines.	5
NJBA members, 6 lines max.	free

New Jersey Blacksmiths Association

NJBA Roster

Achenberg, Len , 5 Hidden Hollow Terr.,
Holmdel, NJ, 07733, 732-739-9391,
preben@home.com

Adkins, Julie , 534 Keebler Rd., King of Prussia,
PA, 19406

Baier, William F., 191 Mt. Pleasant Rd.,
Smithtown, NY, 11787

Barth, David , 3 Washington Ave., Morganville,
NJ, 07751, 732-536-3460,
dsbarth@worldnet.att.net

Bartholet, Sandy , 45F Lafayette Ave, Chatham,
NJ, 07928, 973-635-6445

Bazakas, Peter C. , 354 New Rd., Southampton,
PA, 18966, 215-355-7955

Bienstock, Marshall , 663 Casino Dr., Howell,
NJ, 07731, 732-938-6577, 732-780-0871,
mbienstock@worldnet.att.net

Bornstein, Jay, 81 Sheep Pasture Rd., Setauket,
NY, 11733, ???-246-5270

Bragg, Lester R., 2921 Cleveland Ave.,
Oceanside, NY, 11572, 516-764-5390

Brown, Larry , 90 William Ave., Staten Island,
NY, 10308, 718-967-4776,
lnbrown@con2.com

Butensky, Melissa , 149 Smith St., Apt. 2,
Brooklyn, NY, 11201, 718-625-1938,
melbutensky@yahoo.com

Cassidy, Jim, 35 Clinton St., Center Moriches,
NY, 11934, 516-878-8213

Chobrd, John , 231 Morrison Ave., Hightstown,
NJ, 08520, 609-443-3106, 609-396-9583,
JChob@earthlink.net

Coleman, Walter, 66 West 10th St., Huntington
Station, NY, 11794, 516-271-7923

Crawford, John , 609 Bergen St., Brooklyn, NY,
11238, 718-783-7172

Cruzan, Dan , 146 Harmony Rd., Bridgeton, NJ,
08302, 856-451-0904, dcruzan@jnlk.com

Cuper, Eric K., 331 Contentment Rd., Makanda,
IL, 62958, 908-685-1095

Davison, Carl , 112 N. Putt Corners Road, New
Paltz, NY, 12561, 914-255-8125,
carlrd@worldnet.att.net

Donovan, Patricia , 34 Saint Davids Rd.,
Springfield, PA, 19064, 610-328-2316,
alchemy@bellatlantic.net

Engle, Pete , 47 Center St., Rumson, NJ, 07760,
732-219-6560, pgengle@aol.com

Folk, Jon , P.O.Box 143, Old Bethpage , NY,
11804, 516-474-3109,
rn425268@nassaulibrary.org,
blacksmith@alumni.sunysb.edu

Freeman, Bruce , 222 Laurel Place, Neptune, NJ,
07753, 732-922-8408, 609-716-2827,
freeman@monmouth.com,
freemanb@pt.cyanamid.com

Futer, William , Park Crest Vil 12-A, Glasboro,
NJ, 08028, willy@snip.net

Gambino, Thomas , 92 Halsey Reed Rd.,
Cranbury, NJ, 08512, 609-395-8525

Geist, George, 87 Devon Ave., Spotswood, NJ,
08884, 732-251-1922

Gerhauser, Bill , 415 Hutchinson St., Hamilton,
NJ, 08610, 609-394-1817

Gichner, Bill, Box 8, Bethany Beach, DE. 19930,
302-539-6974

Giumetti, Hector , 466 Freund Ave., Gibbstown,
NJ, 08027, 609-423-3747, 609-423-3524,
hagiumetti@home.com

Glynn, Thomas , 278 Sterling Pl, Brooklyn, NY,
11238, 718-638-5739, thomglynn@aol.com

Goldman, Jerry , 1143 Virginia Ave., Cape May,
NJ, 08204, 609-884-3821

Grabowski, Ron, 110 Burlington Blvd.,
Smithtown, NY, 11787, 516-265-1564

Grasso, Joe , 191 Rockaway Pkwy., Valley
Stream, NY, 11580, 516-561-7963,
718-768-7186, joetoolie@aol.com

Harbert, Donald D. , 222 Mill Road, Marlton,
NJ, 08053, 856-767-5807

Hart, E. Lee , 115 Milton Dr., Thornwood, NY,
10594, 914-769-6438

Hay, Jr., Bruce , 50 Pine St., Lincroft, NJ,
07738, 732-747-4758

Helstrom, Jim , 6391 Ferry Rd., Doylestown, PA,
18901, 215-297-8247, 215-236-7041,
litlbean@bellatlantic.net

Hilmer, Heinz K. , 40-14 68 Street, Woodside,
NY, 11377, 718-426-3886

Holcombe, Richard, #8 Zieglers Lane, Hamilton
Square, NJ, 08690, 609-587-1097

Holstrom, Anton , 26 Saddle Shop Road,
Ringoos, NJ, 08551, 609-466-0349

Holzmacher, Roger, 31 Willow St., Babylon,
NY, 11702, 516-661-0294

Holzman, Robert , 9 Jodi Lane, New City, NY,
10956

Huebner, Rudy , 9302 Andover Rd.,
Philadelphia, PA, 19114, 215-671-8373

Jani, Ron , 11 McKinley Dr., Rockaway Boro,
NJ, 07866, 973-625-5442, 201-934-7600,
BlkPnFrg@aol.com

Jones, Jason, I.b. Nashville Ave., apt. #1,
Ventnor, NJ, 08406. (???) 624-1556

Kaufman, Philip F. , 1333 Michael Road,
Meadowbrook, PA, 19046, 215-576-1265,
patnphil@voicenet.com

New Jersey Blacksmiths Association

- Kavett, Joshua , 471 Casino Dr., Farmingdale,
NJ, 07727, 732-431-2152, jakavett@aol.com
- Ker, Bill , Box 14, Allenwood, NJ, 08720,
732-223-4188, KemoKimo@aol.com
- Ketchersid, Paul A., 19 Lorraine Terrace,
Boonton, NJ, 07005. 973-334-3469,
201-818-8219, pak@interactive.net
- Knudson, C. William , PO Box 53, Palisades,
NY, 10964, 914-359-0160,
aiyana@acd-pc.com
- Landmesser, Eric , 118 Patton Ave, Pine Beach,
NJ, 08741, 732-240-3062, 732-349-6185*,
elandmes@tomsriver.kiz.nj.us
- Learn, Doug , 121 Pebble Woods Drive,
Doylestown, PA, 18901, 215-489-1742,
215-443-8710, doug.learn@Primedica.com or
cjdlear@bellatlantic.net
- Longo, Doug , 36 Britton St., Madison, NJ,
07940, 973-514-2044, 973-575-4004
- Macauley, David , 4 Patricia Ct., Howell, NJ,
07731, 732-206-1568, 732-949-8422,
drm@anchor.ho.att.com
- Machovec, Miro , 1036 Willowbrook Rd., Staten
Island, NY, 10314, 718-494-6107,
718-816-8660
- McAllister, Jim, 214 8th St., Hicksville, NY,
11801, 516-433-1949
- McLaughlin, John, 458 W. Fulton St., Long
Beach, NY, 11561, 516-432-9116
- McLaughlin, Leo J., 78 Lincoln St., Howell, NJ,
07731, 732-370-5107
- Meshejian, Mardi, 33 Elm Dr., East Northport,
NY, 11731, 516-231-0085, 516-757-4541,
mardi@gypsilodge.com
- Miller, Tim, 4 Browns Lane, Bellport, NY,
11713, 516-286-0351, 516-398-2824
- Mills, Mike , 16 N. Main St., Cape May Ct.
House, NJ, 08210, 609-465-4443,
609-886-1455
- Mirenda, Samuel , 508 S. Lehigh Rd., Glassboro,
NJ, 08028, 856-881-5016
- Molnar, Tom , 281 Goat Hill Road,
Lambertville, NJ, 08530, 2001, 609-397-1365,
609-267-4226 x303,
STMOLNAR@WEB-ITSHOW.COM
- Monsen, Arthur M. , 5 Brooktree Rd., East
Windsor, NJ, 08520, 609-448-4454,
blacksmith4art@yahoo.com
- Morelli, Jeff , 234 Rahilly Road, Wrightstown,
NJ, 08562, 609-723-5990, 732-494-9061
x1162
- Nelson, Norman , 199 School Road East,
Marlboro, NJ, 07746, 732-462-6093
- Norris, Paul, P.O. Box 1406, Greenwood Lake,
NJ, 10925, 914-477-3470
- Papp, Alan , 167 Dey St., Jersey City, NJ, 07306
- Pettengill, Nate , 24 Byron Rd., Short Hills, NJ,
07078, 856-608-6324,
npetteng@motown.lmco.com
- Phillips . Greg. 737 Route 17K, Montgomery,
NY, 12549, 914-457-5671,
suresign@frontiernet.net
- Reilly, Thomas , 360 Page Ave., Lyndhurst, NJ,
07753, 201-939-2287 or 201-998-0149
- Rhoades, Steven W. , 513 Harding Highway,
Vineland, NJ, 08360, 856-697-4144,
hotiron1@juno.com
- Ringier, Bruce , 618 Mazur Ave., Paramus , NJ,
07652, 973-875-5200, 201-652-4526
- Ritsert, Gene , 17 Pleasant Ave., Beesleys Point,
NJ, 08223, 609-390-0317
- Scarlett, Bob , 414 Montclair Dr., Pleasantville,
NJ, 08232, 609-641-5322
- Schweikert, Don, 38 Hopkins St., Sayville, NY,
11782, 516-589-3970, dschweik@juno.com
- Spoerri, William , HC 62 Box 820, Honesdale,
PA, 18431, 717-729-8815
- Strom, Raymond, 37 Beverly Ave., East
Patchogue, NY, 11772, 516-475-9361
- Stryker, Hugh J. , 63 Sandy Point Dr., Brick, NJ,
08723, 732-447-9266
- Suhaka, Ben , 715 Haran Ave., Manville, NJ,
08835, 908-722-8197, ben@mail.superlink.net
- Suter, Tim , 1112 Ladner Ave., Gibbstown, NJ,
08027, 856-423-4417
- Tindall, L. Curtis , 36 Elm Terr., Flemington, NJ,
08822, 908-806-3856
- Tomczyk, Robert , 25 Virginia Ave., Livingston,
NJ, 07039, 973-992-3102
- Vecchio, John, 31 Woodland Dr., East Islip, NY,
11730, 516-581-3169
- Vida-Szucs, Andy , 13 Old Monmouth Rd.,
Freehold, NJ, 07728, 732-308-9039,
732-957-6043, osan@netlabs.net
- Wardwell, Paul, 2458 East 24th St., Brooklyn,
NY, 11235
- Watkins, Larry, 27 Corson Ave., Mercerville,
NJ, 08619, 609-586-1916, 856-787-3509,
watkins@bigplanet.com
- Williams, Gary , PO Box 479, Quakertown, NJ,
08868, 908-735-6241, 908-337-1838,
garywilliams@erols.com
- Wolfe, Lincoln , 11 Overlook Terrace,
Bloomfield, NJ, 07003, 973-338-3913,
201-804-5020, clincolnw@aol.com
- Zeltmann, Jeremiah, 23 Kalmia St., East
Northport, NY, 11731, 516-754-3461
- Ginty's Welding Sevice, Inc., 2 Lee Mack Ave.,
Danbury, CT, 06810

NJBA Roster Indexed By City and State

New Jersey

Allenwood	Bill Ker
Beesleys Point	Gene Ritsert
Bloomfield	Lincoln Wolfe
Boonton	Paul A. Ketchersid
Brick	Hugh J. Stryker
Bridgeton	Dan Cruzan
Cape May	Jerry Goldman
Cape May Ct. House	Mike Mills
Chatham	Sandy Bartholet
Cranbury	Thomas Gambino
East Windsor	Arthur M. Monsen
Farmingdale	Joshua Kavett
Flemington	L. Curtis Tindall
Freehold	Andy Vida-Szucs
Gibbstown	Hector Giumetti
Gibbstown	Tim Suter
Glasboro	William Futer
Glassboro	Samuel Mirenda
Hamilton	Bill Gerhauser
Hamilton Square	Richard Holcombe
Hightstown	John Chobrda
Holmdel	Len Achenberg
Howell	Marshall Bienstock
Howell	David Macauley
Howell	Leo J. McLaughlin
Jersey City	Alan Papp
Lambertville	Tom Molnar
Lincroft	Bruce Hay, Jr.
Livingston	Robert Tomczyk
Lyndhurst	Thomas Reilly
Madison	Doug Longo
Manville	Ben Suhaka
Marlboro	Norman Nelson
Marlton	Donald D. Harbert
Mercerville	Larry Watkins
Morganville	David Barth
Neptune	Bruce Freeman
Paramus	Bruce Ringier
Pine Beach	Eric Landmesser
Pleasantville	Bob Scarlett
Quakertown	Gary Williams
Ringoes	Anton Holstrom
Rockaway Boro	Ron Jani
Rumson	Pete Engle
Short Hills	Nate Pettengill
Spotswood	George Geist
Ventnor	Jason Jones
Vineland	Steven W. Rhoades
Wrightstown	Jeff Morelli

New York

Babylon	Roger Holzmacher
Bellport	Tim Miller
Brooklyn	Melissa Butensky
Brooklyn	John Crawford
Brooklyn	Thomas Glynn
Brooklyn	Paul Wardwell
Center Moriches	Jim Cassidy
East Islip	John Vecchio
East Northport	Mardi Meshejian
East Northport	Jeremiah Zeltmann
East Patchogue	Raymond Strom
Greenwood Lake	Paul Norris
Hicksville	Jim McAllister
Huntington Station	Walter Coleman
Long Beach	John McLaughlin
Montgomery	Greg Phillips
New City	Robert Holzman
New Paltz	Carl Davison
Oceanside	Lester R. Bragg
Old Bethpage	Jon Folk
Palisades	C. William Knudson
Sayville	Don Schweikert
Setauket	Jay Bornstein
Smithtown	William F. Baier
Smithtown	Ron Grabowski
Staten Island	Larry Brown
Staten Island	Miro Machovec
Thornwood	E. Lee Hart
Valley Stream	Joe Grasso
Woodside	Heinz K. Hilmer

Pennsylvania

Doylestown	Jim Helstrom
Doylestown	Doug Learn
Honesdale	William Spoerri
King of Prussia	Julie Adkins
Meadowbrook	Philip F. Kaufman
Philadelphia	Rudy Huebner
Southampton	Peter C. Bazakas
Springfield	Patricia Donovan

Connecticut

Danbury	Ginty's Welding Sevice, Inc.
---------	------------------------------

Delaware

Bethany Beach	Bill Gichner
---------------	--------------

Illinois

Makanda	Eric K. Cuper
---------	---------------

New Jersey Blacksmiths Association

NJBA Roster Indexed by First Name

Alan Papp	Eric Landmesser	Jon Folk	Philip F. Kaufman
Andy Vida-Szucs	Eric K. Cuper	Joshua Kavett	Raymond Strom
Anton Holstrom	Gary Williams	Julie Adkins	Richard Holcombe
Arthur M. Monsen	Gene Ritsert	Larry Watkins	Robert Holzman
Ben Suhaka	George Geist	Larry Brown	Robert Tomczyk
Bill Gichner	Ginty's Welding Sevice	Lee Hart	Roger Holzmacher
Bill Gerhauser	Greg Phillips	Len Achenberg	Ron Grabowski
Bill Ker	Hector Giumetti	Leo J. McLaughlin	Ron Jani
See also: William	Heinz K. Hilmer	Lester R. Bragg	Rudy Huebner
Bob Scarlett	Hugh J. Stryker	Lincoln Wolfe	Samuel Miranda
See also: Robert	Jason Jones	Mardi Meshejian	Sandy Bartholet
Bruce Freeman	Jay Bornstein	Marshall Bienstock	Steven W. Rhoades
Bruce Hay, Jr.	Jeff Morelli	Melissa Butensky	Thomas Gambino
Bruce Ringier	Jeremiah Zeltmann	Mike Mills	Thomas Glynn
Carl Davison	Jerry Goldman	Miro Machovec	Thomas Reilly
Curtis Tindall	Jim Cassidy	Nate Pettengill	Tim Miller
Dan Cruzan	Jim McAllister	Norman Nelson	Tim Suter
David Barth	Jim Helstrom	Patricia Donovan	Tom Molnar
David Macauley	Joe Grasso	Paul Norris	Walter Coleman
Don Schweikert	John McLaughlin	Paul Wardwell	William Futer
Donald D. Harbert	John Vecchio	Paul A. Ketchersid	William Knudson
Doug Learn	John Chobrda	Pete Engle	William Spoerri
Doug Longo	John Crawford	Peter C. Bazakas	William F. Baier

Snub End Scroll Starter

Seems that whenever I make snub end scrolls, I end up with a flat spot. Bob recommends making a starter from a small section of pipe with an inside diameter slightly larger than the snub end. Cut a slot in the pipe and sharpen the edges with a file.



CUT A
SLOT



GRIND THE
EDGES

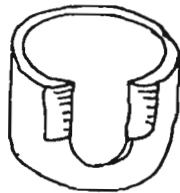

FLATTEN THE END
TO USE IN A VISE

OR



WELD A HARDY
STEM INSIDE PIPE

Reprinted from:
Appalachian Area Chapter Newsletter

April, 1999

WHEN I WAS A LAD

BY CHARLIE SUTTON

This is an expression that us Old Codgers will use from time to time. After reaching the age of seventy a man can use this expression with impunity. So I intend to make the most of this privilege and write this column for the Newsletter. I hope you will find it interesting, amusing and informative.

“Batter Up”

Anvil tools are extremely handy and allow you to do all kinds of anvil functions and techniques. There is a drawback when using anvil tools; you need a helper, called a striker. The striker will provide the hammer blows when you use them. In the shop where I worked blacksmith strikers were classed as semi skilled labourer. Their skill in using sledgehammers came from years of experience. Many people would say that a blacksmith was only as good as his striker. A good blacksmith/striker relationship was a joy to watch. The rhythm, the cadence, the moves, the timing was as graceful as a fine ballet.

At this point let me introduce you to Ralph Batey, Geordie to his friends. Geordie was Wilkie's striker. They had worked together for many years and when I first saw them working I was amazed. Hardly a word passed between them. When working on the anvil they seemed to anticipate each other, they had a range of subtle signals, an incline of the head, a nod, taps on the anvil with the hammer by the smith, it was complete, mutual understanding and I was to learn this skill over the years. Blacksmith striking was a trade unto itself. It took many years of working until a striker was proficient with the sledge. It was not a matter of strength; it was matter of cadence and technique. I was to get my grounding from Geordie.

My second day in the shop he called me over. He gave me two sledgehammer heads, one weighing 7lbs and the other 14lbs. They were brand new and he had just drawn them from the shipyard store. “These are yours lad” he said, “and I don't care if you hit with them so hard that you break them. I can always get more.” He was smiling at his own humour. He produced two hammer shafts and proceeded to show me how to install them in the heads. He measured my arms and cut the shafts to the right length and then instructed me how to use them. “Never, never hit the anvil with your sledge. That is the smith's job” he said, meaning the light taps with the hand hammer with which the smith maintained an all-important rhythm.

Heavier blows would mar the surface of the anvil. He taught me how to use the sledge with energy saving efficiency. With the left hand at the end of the shaft allow it to fit into the left leg at the groin, the right hand under the head, it's easier to lift from there. Use the left leg to kick the hammer forward and help the right hand to raise it above the head. Next, slide the right hand down the shaft and allow the head to drop as you aim it at the spot that the smith has indicated with his hand hammer. “Allow it to drop son” he said “That's the secret. Always let the hammer do the work.”

When my lesson was completed he said, “Now you are going to be the Spare Jerk. You will stand in the middle of the shop and when a smith has a job that requires double batting (two strikers) he will yell, “Batter Up” as he comes to the anvil and you will run over and join the other striker.” Easier said than done. By the time I would reach the anvil the striker was already working and I had to fit in very smoothly. Even today I have a very good sense of rhythm, inherited from my days as a Spare Jerk. When I'm at the ballpark and someone yells, “Batter Up” it has a different connotation for me and it reminds me of Geordie Batey.

There were many tools that were used on the anvil for the smith and striker to use to accomplish the job. Most of these were standard blacksmiths tools with a handle on the top tool for the smith to hold and a square shank on the bottom tool which would fit into the square hole in the anvil.

The hot set, for cutting hot metal, came in different shapes and sizes depending on the job to be done. Some were rounded to form a “C” cutting edge and used for rounding corners on flat stock, strangely these were called “C” sets. The cold set was stubbier and used for cutting or marking steel cold.

The flatter had a face about 3” square and the edges were rounded to prevent them from digging into the hot metal. It was used to dress out any hammer marks and to make a smooth finish on the piece you were working on. The set hammer was similar to the flatter but about 2” square and sharper corners so that it would form a ridge in the hot metal when struck with the sledge.

Fullers were very adaptable and used for many functions, necking down, scarfing forge welds and for drawing out stock. The swage, a cousin of the fuller, was used to accurately round a drawn down piece of metal. In the shop we were required to perform the swaging so that the piece could be threaded with dies.

The Iron Trillium

Reprinted from:

“When I Was a Lad” continued....

It isn't everyone that is fortunate enough to have a blacksmith striker as a buddy, so ways have to be devised so that you can handle anvil tools. The hot and cold hardies are handy for cutting steel and these are made so that they will fit in the square hole in the anvil, hence the “Hardie Hole”. A spring fuller that also fits the hardie hole is a very helpful tool. By using

your creativity you can devise all kinds of useful tools.

Then there is the “third hand”, a clamp tool rest, or hold-down that holds the work steady and allows you to hold the handle of the tool in one hand while you use a heavy hand hammer in the other, thereby acting as your own striker. So when you need a “Batter up” it will have to be yourself. Not like it was “When I was a Lad”

Individual Statements On Drawing

Compiled by Jack Andrews for the
ABANA 1998 Asheville Conference

The impulse to draw is as natural as the impulse to talk. As a rule, we learn to talk through a simple process of practice, making plenty of mistakes when we are two and three and four years old-but without this first effort at understanding and talking it would be foolish to attempt to study grammar or composition. It is this vital preparation, this first mouthing of the words which mean actual things, that parallels the effort a student should make during the first years of his art study.

Nicolaides, Kimon.,

The Natural Way to Draw

From an early age, perhaps the age of eight or nine, I was able to draw fairly well. I think I was one of those few children who accidentally stumbles upon a way of seeing that enables one to draw well. I can still remember saying to myself, even as a young child, that if I wanted to draw something, I had to do 'that.' I never defined 'that' but I was aware of having to gaze at whatever I wanted to draw for a time until 'that' occurred.

Then I could draw with a fairly high degree of skill for a child.... I knew that drawing was easy and

that all anyone had to do was to look at things in that certain way. Edwards, Betty. Drawing on the Right Side of the Brain

If the misconception about 'drawing talent' were applied to verbal expression, we'd be a nation of illiterates. To be sure, there are visually talented people, just as there are verbally apt poets, novelists, and speakers. More to the point, the impulse to draw is universal in young children, despite the common scarcity of parents who draw. Were education to nurture this natural drawing impulse, as it does reading and writing, virtually everyone would draw. McKim, Robert.

Experiences in Visual Thinking

The young man who thinks of learning blacksmithing...should study freehand drawing. Every hour spent at the drawing board is a hour spent shaping irons, as he is training the hand to perform the work and the eye to see that is true. And at no time should he drop the pencil. He should keep in mind the fact that the most skillful are the most successful. We do not mean skillful in one line only, but in all.

Richardson, M. T. Practical Blacksmithing, vol. 3

Father (Samuel Yellin) felt strongly about drawing. I can remember him going to bed and drawing, sometimes late into the night. He would then take these drawings into the shop and have his best men work them out in iron. He would even go in on Sundays and light a forge to do a test piece from these drawings. Father would often say, "I've got all of these ideas going around in my head and I have to draw them out so that I don't forget them." Harvey Yellin in a conversation with Jack Andrews around 1981.

Later, I found in the dark room a drawing on a shirt cardboard that Yellin had drawn. It was of several twisted links. On the bottom of the drawing was the notation, "Save this drawing, something may come of this. SY" This motif was later used in a gate for the Washington Cathedral forged by Fred Crist and fabricated in the shop on Arch Street.

Jack Andrews

One should never lose sight of the fact that iron remains hot and pliable only when it has just come from the fire, and that whatever is to be done, must be accomplished without hesitation; a simple drawing will be a help, an involved one a hindrance. Geerlings, Gerald K. Wrought Iron in Architecture.

A Small Forge

By Brian Gilbert

Here's the design for the small forge tables that were built for the Madison Conference. The original table design was adapted from one shown in the Illinois Valley Blacksmith Association Newsletter, but we've changed the design quite a bit. They're small, and somewhat portable due to their size.

This forge is designed to work with the small smoke hood that was shown in the last month's issue. One of the problems we ran into while building these was that the hoods were just a bit wider than the tables, so we had to fuss around quite a bit to get them to fit... moral of the story, check the hood width before cutting the steel for the tables.

Most of the materials can be changed to suit whatever steel you have on hand. For example, we used 1 1/2" x 1/8" angle for the table frame. If you've got a bunch of 2" lying around, go for it!

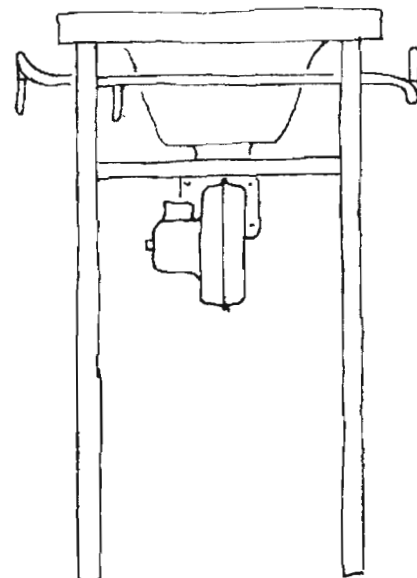
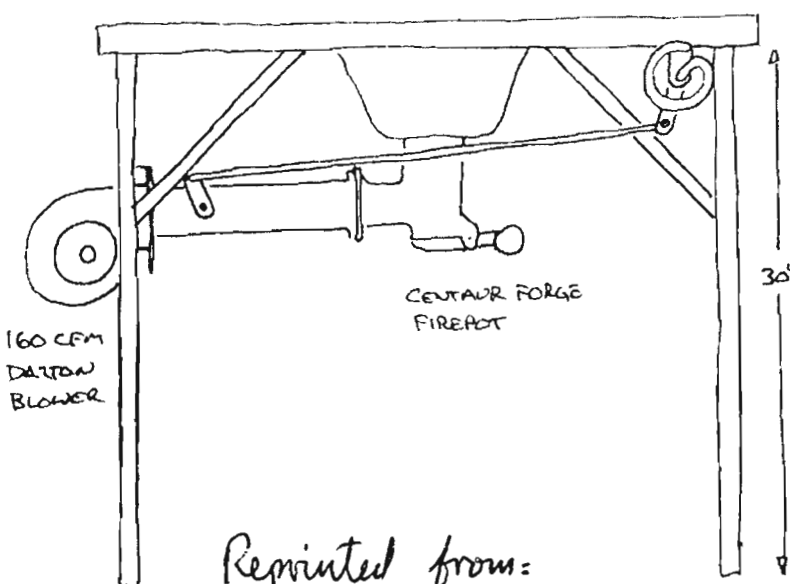
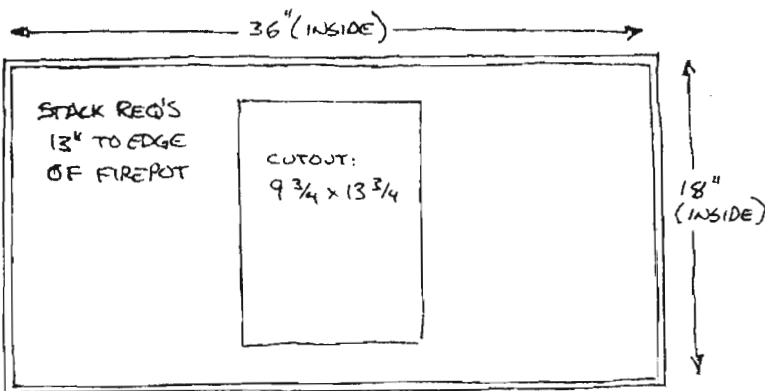
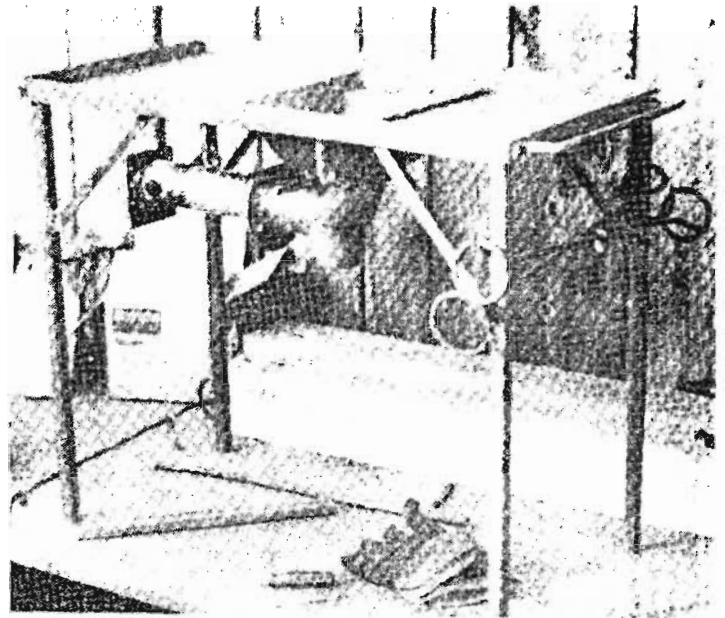

Reprinted from:
Appalachian Area Chapter Newsletter

April, 1999

Welding Your Own Firepots

Here's yet another idea from Lonnie Farmer. You can weld up your own firepots with a handful of steel and some welding rod. Several of these have been built by Lonnie for the Boy Scout summer camp. Lonnie teaches piles of adolescent boys blacksmithing in July and August... in the sunshine. Last year he lost twelve pounds the first week, and it may have affected his mental state, because he's going to do it again this year. Anyway, the dimensions for this firepot are nominal, and were taken to approximate the Champion firepots we have at the shop. One of the features of these is the use of square tube for the air supply instead of pipe. This makes cutting and assembly much easier. You could cut an optional notch in the sides for long bar clearance, but that would complicate matters somewhat. While these firepots aren't quite as nice as a commercial model... they don't have a chinker breaker... they are cheaper and work fairly well.

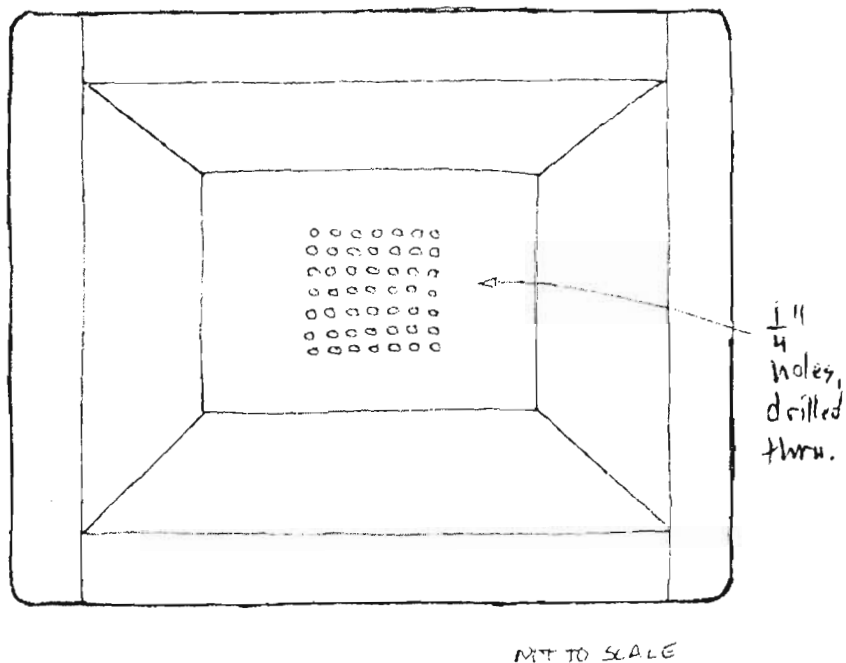
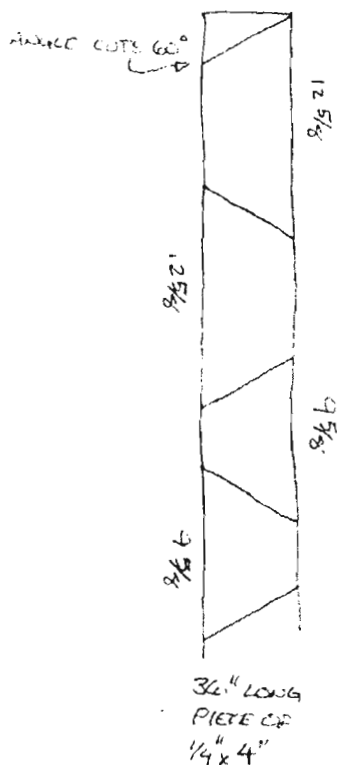
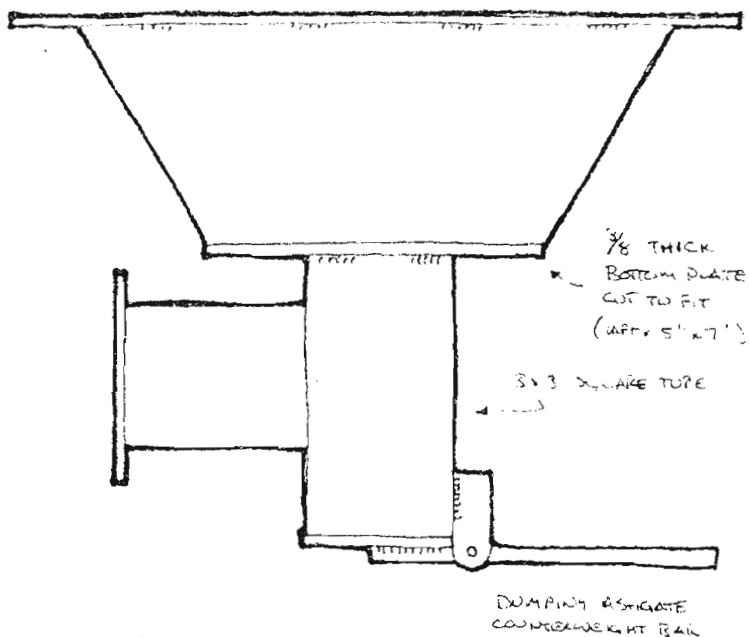

Reprinted from:

Appalachian Area Chapter Newsletter

March, 1999

Page 10

αβχδεφγηηθικλμνοπρστυωξψζαβχδεφγηηθικλμνοπρστυωξψζαβχδεφγηηθικλμνοπρστυωξψζ

♣ A Demonstration by Master Blacksmith Peter Ross ♣

from the note and sketch books of Frank Turley and James Baniecki

NAIL HEADER TOOL

Over all Length = 10 1/16"

□ This tool was/is used to make square nails contemporary to those made in the pre-Revolutionary English colonies.

Peter said his shop made 20,000 such nails one particular year!

□ See nail in process fig. G (below)

□ This detail of the bottom of the Header shows the Pritchel Hole Lug.

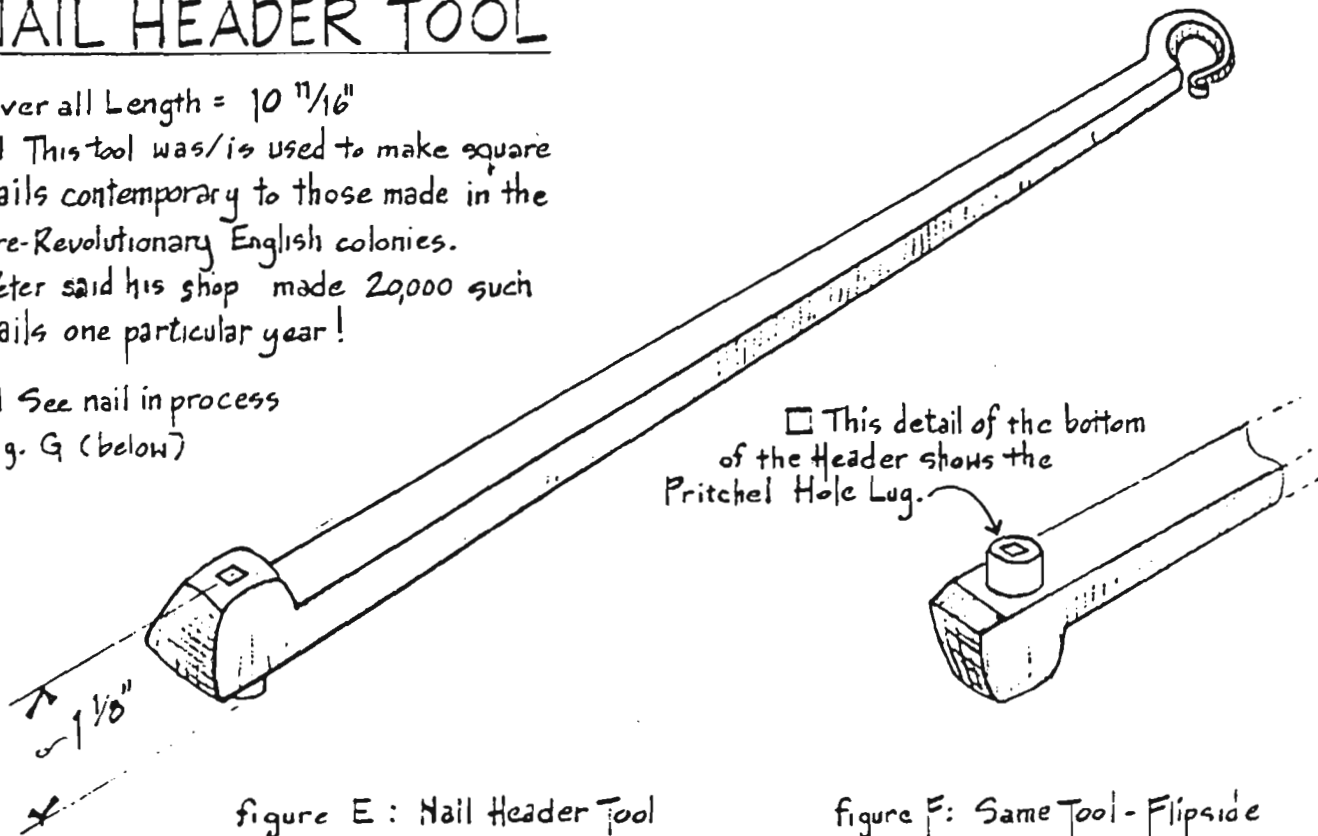

figure E : Nail Header Tool

figure F: Same Tool - Flipside

MAKING THE NAIL

□ Peter began with a 1/4" Ø steel rod, and first tapered the rod to a point at the far Anvil edge.

□ Now drop back a known distance from the point and shoulder on two sides at the near Anvil edge with half face blows.

□ Peter makes two hardie cuts and inserts the nail in the header tool, with the "Lump" away from him (breaking the nail off of the rod as he does so.)

□ The nail head is then made with angle blows in order to center and flatten the head - as well as to give the head facets.

Figure G : Nail in Process - Two Views

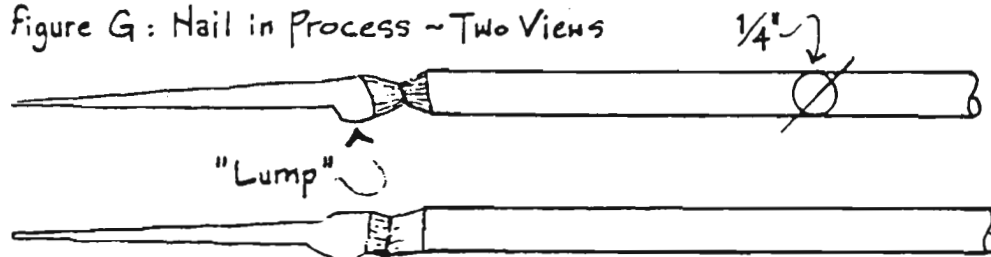

Reprinted from:
APPALACHIAN AREA
CHAPTER NEWSLETTER

APRIL 1993

Doug Merkel Style Nail Header

by Kit Wattenbarger

Most of the smiths I talk with have had problems with the production of quality yet quickly made nail headers with the result that novices find the project daunting and the rest of us either have tied up a lot of time with our header(s) or do not have either the variety of styles/sizes or quality we would be proud to show off. Doug Merkel has developed and demonstrated a simple method to make rather elegant and good quality metal headers with a minimum of effort allowing the smith to quickly make a number of headers for different size/style nails.

1. Heat a 4 inch piece of truck axle or shaft of slightly larger diameter than the anvil hardy hole to forging heat



2. Preferably with a striker, place the axle over the anvil hardy hole overlapping by approximately 1/2 inch. Evenly flatten the length of the axle over the anvil; this will drive part of the stock down into the hardy hole and leave a mounded up area of your stock that becomes the working portion of your header.

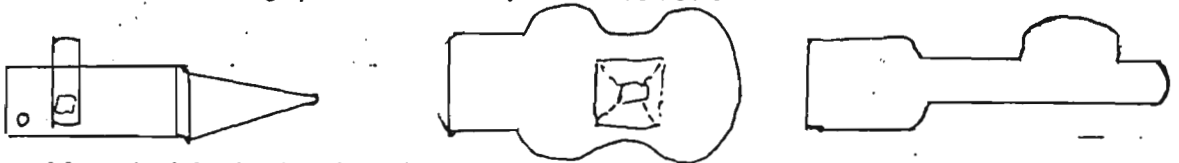

3. Fuller behind the header stock and draw out the handle of your choice.

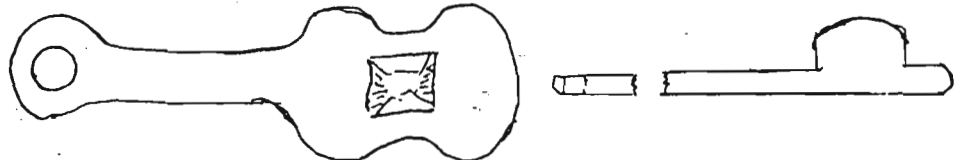

4. Anneal the header and drill a hole thru the top of the header to the back. 3/16 inch works well for general purpose nails.

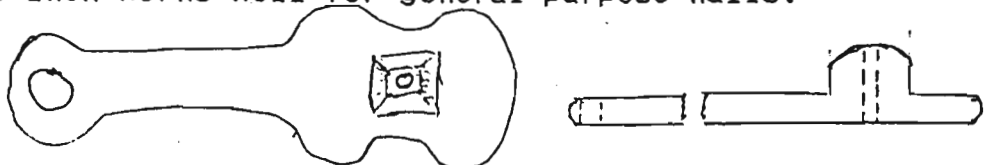

5. Finish the header, then harden and temper as desired. After the first half dozen nails, the header bore is cleaned, smoothed, and ready for years of use.

Rivet Tool

Doug Wilson adds his mark to this useful tool

- Ian Walker

This is a handy tool for making various size rivets from round stock. The end of the round stock is heated, the stock clamped in the tool between vise jaws, and the head is formed.

One variation of this tool (Fig. 1) appeared in the Bellows and Breeze, newsletter of the New Zealand Blacksmiths.

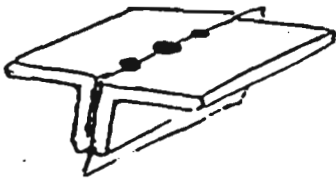

Fig. 1 Angle Iron

Two pieces of thick angle iron the length of the vise jaws are clamped together as shown with a thin strip of card (a business card, for example) between them, and several holes the size of the required rivet shanks are drilled down the joint. The top edges of the holes are eased with a round file.

To use the vise, clamp the angle iron pieces together with a piece of round stock, leaving a suitable amount of material above the angle irons, and forge the head.

A variation of this tool (not shown) is made from a single piece of angle iron about 10 inches long. The web is cut through on one side, the middle heated, and the two five-inch long ends folded back on themselves. The finished tool is similar to the New Zealand tool, but is in one piece, not two.

I had seen a Rivet Heading Tool

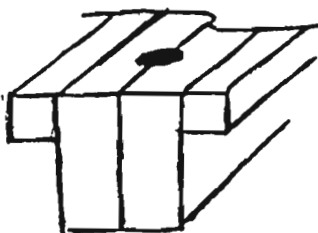

Fig. 2 Bar Stock

Bruce Freeman, editor

Tim Suter, assistant editor.

Volume 4, Number 2

September, 1999

page 14

in Doug Wilson's Deer Isle, Maine shop made from bar stock (Fig. 2).

Doug said he got the idea from Francis Whitaker. Doug's rivet tool is made from two pieces of 3/4" x 1-1/2" bar and a single piece of 1/2" square stock that has been tapered at the center and bent into a "U" form. He prefers to use bar stock because, unlike angle iron which has an inside radius where the webs join, the bar stock can be assembled with a clean 90 degree angle so that the tool sits down solidly on the vise.

Doug said he'll make his next rivet tool with the 1/2 inch stock welded lower on 3/4" x 2" bars so that the top can be tapered (Fig. 3), thus getting the tool out of the way of the hammer head.

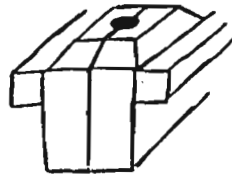

Fig. 3 Modified Bar Stock
Doug's other suggestions:

1. Assemble before drilling the holes.
2. For hot rolled rivet stock, drill the holes -1/64 inch. For cold rolled stock, - 1/32 inch. Use a card spacer.

Doug says that Francis drills slightly smaller holes and taps them to form very shallow grooves which help grip the rivet stock.

3. It is essential to relieve (file or slightly countersink) the top of the holes or the sharp junction between the rivet head and rivet shank will tend to be weak.

4. Doug leaves between 2 and 2.5 times the diameter of the rivet stock extending above the

tool. His rivet heads are frequently decorative, and he doesn't like them "dinky." But you should experiment.

5. Bring the rivet shank to a bright heat below the top of the tool so that the rivet shank seats well in the radius formed at the top of the tool.

6. Leave the partially formed rivet in the tool, reheat with a torch, and finish forming the head. Do any decorative work at this stage.

(Note: hammering on the rivet head after it is in place in your project will risk damage to the work.)

7. Remove the finished rivet from the tool, hook the head over an anvil edge, mark the rivet with chalk using a measured distance marked on the anvil, and sever the rivet on a hot cut in the hardie hole. Return rivet stock to fire while hot, repeat. Don't waste heat by cooling, sawing, and reheating.

8. When installing back up decorative rivet heads with a thick copper plate to prevent their being damaged.

9. Use modeling clay to experiment with decorative rivet head patterns.

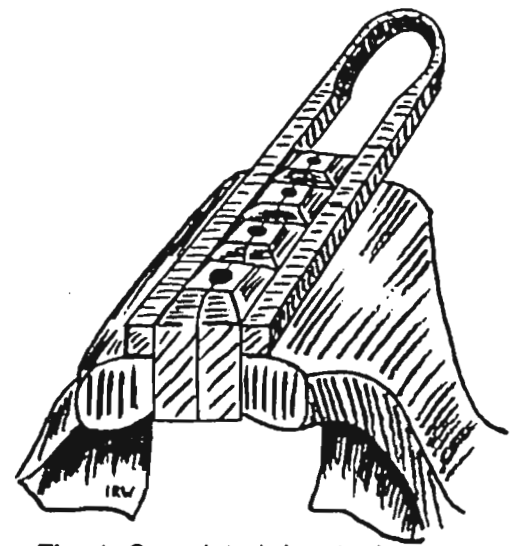
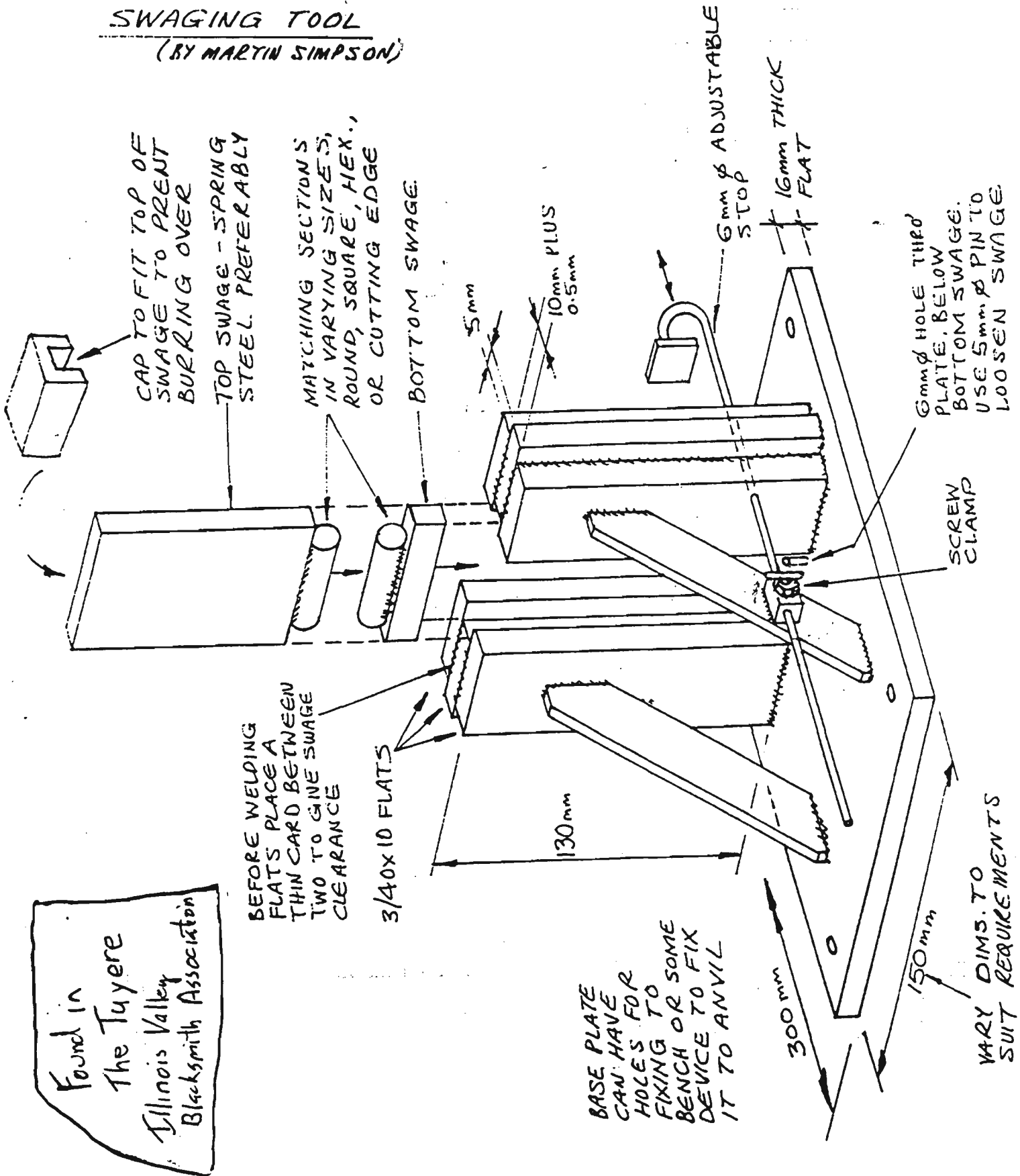

Fig. 4 Completed rivet tool shown in vise

Reprinted from: Newsletter of the New England blacksmiths

SWAGING TOOL
(BY MARTIN SIMPSON)



The Belgian Hardie

An Asheville Surprise!

by Mark Smith

One of the pleasant surprises at ABANA's Asheville Conference this summer was Roger Bockstaele from Belgium. Roger is a retired machinist who forges as a hobby in the attic of his home.

When I watched him work, making leaves, bird feet, feathers, and human figures, they revolved around the tool illustrated here.

From dragons to owls, eagles attacking serpents and ants to praying mantises, his work was very realistic. My writing skills cannot do it justice. I will remember it as pure enjoyment; to see Roger Bockstaele forge and see his work. ★

Reprinted from the TABA Pennsylvania Stripper

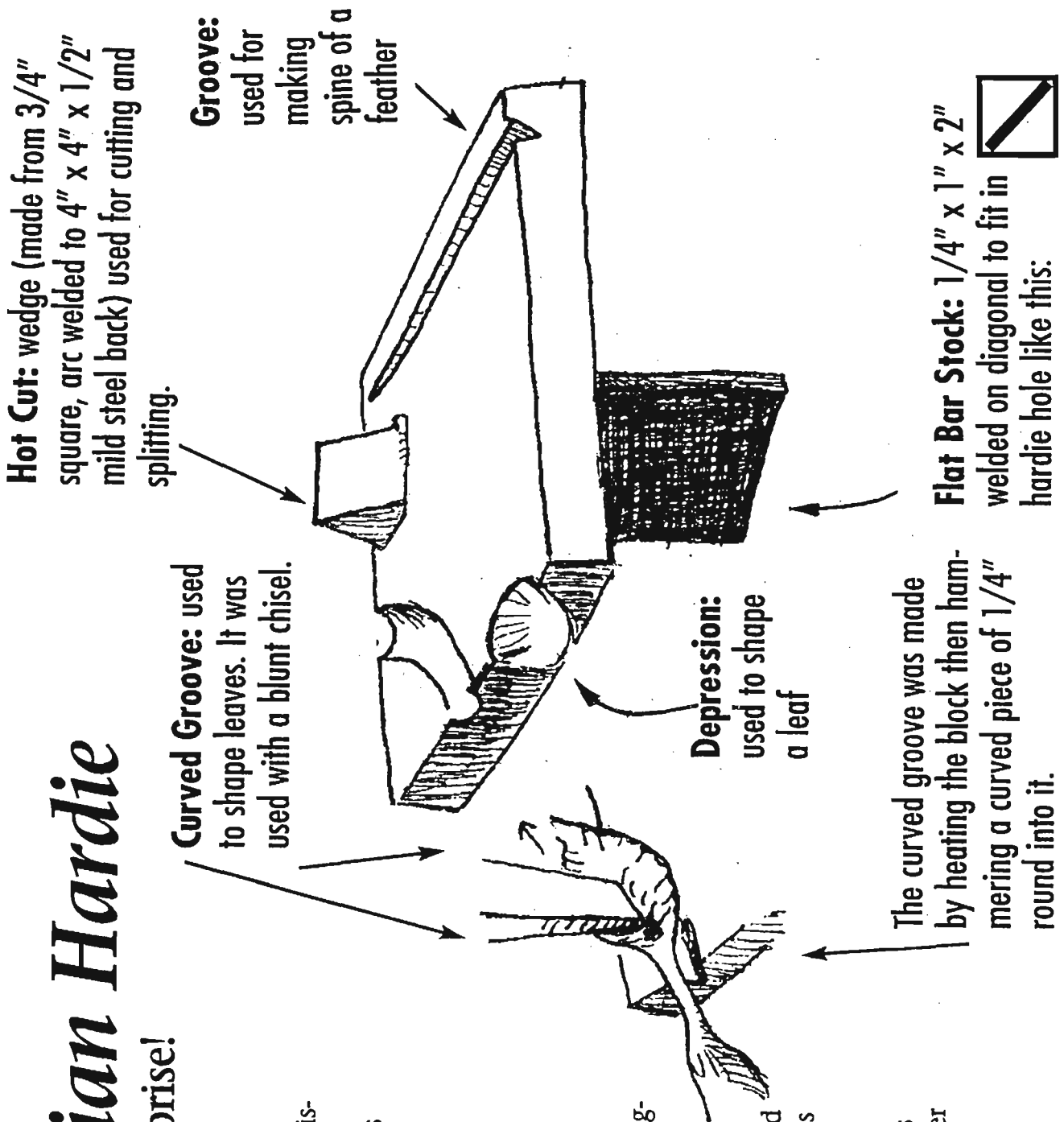

Hot Cut: wedge (made from 3/4" square, arc welded to 4" x 4" x 1/2" mild steel back) used for cutting and splitting.

Groove: used for making spine of a feather

Curved Groove: used to shape leaves. It was used with a blunt chisel.

Depression: used to shape a leaf

Flat Bar Stock: 1/4" x 1" x 2" welded on diagonal to fit in hardie hole like this:

The curved groove was made by heating the block then hammering a curved piece of 1/4" round into it.

More on Tongs

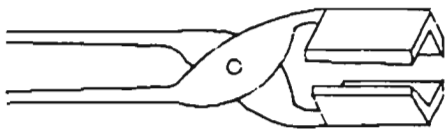

The "V" notch jaw can hold round or square stock securely.

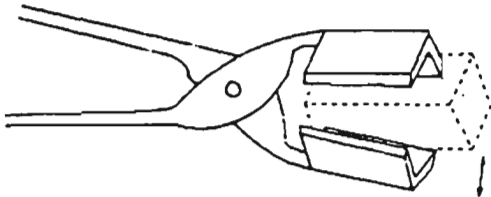

As long as the stock is relatively near the designed size.

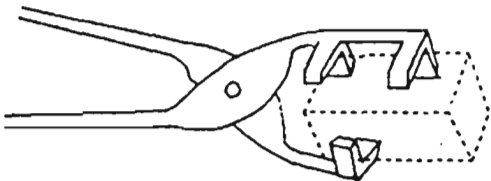

The three point contact tong is a modification which improves considerably the range of sizes of material which the tongs can be expected to hold securely. In fact, it can grip flat stock in a vertical or horizontal position.

The question is "HOW TO MAKE 3 POINT V NOTCH TONGS".

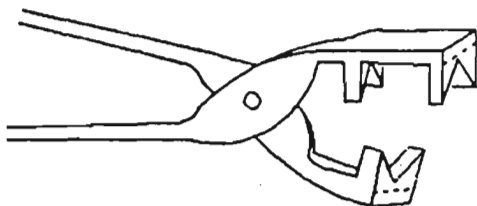

You could arc weld notched jaws to a pair of flat jawed tongs.

This produces a very nice set of tongs as Joe Farina, JC Hawkins and others have demonstrated.

However, if you want something different made from the old technique without any welding and starting from your own formula for making bosses and flat jaws turn the page and read on.

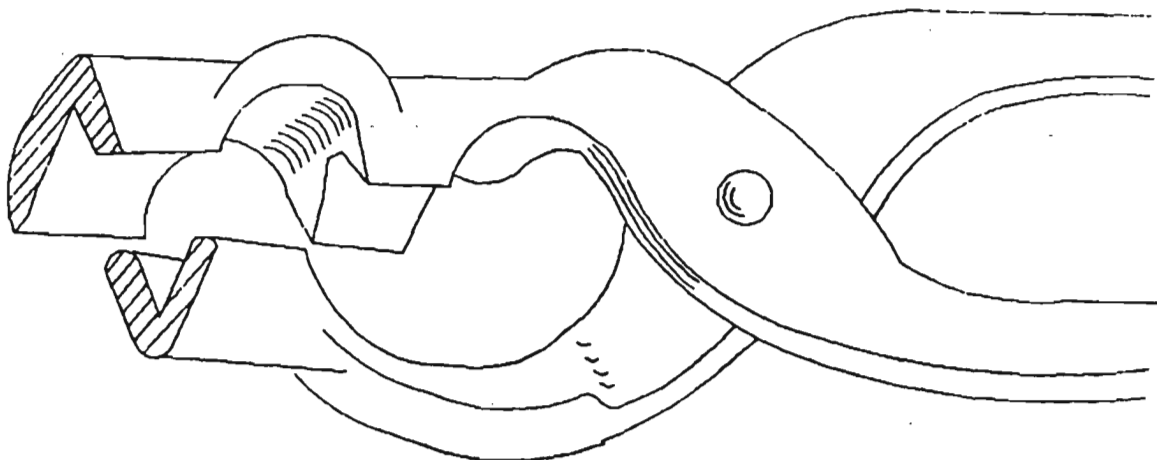

By Dale F. Kipp
Bradenton, Fla.

New Jersey Blacksmiths Association

First make a pair of flat jawed tongs, I started with 5/16" rod and flattened the jaws to 1/4" x 3/4" x 3". Then I formed the boss using a technique which provided a lot of space between the jaws at the boss.

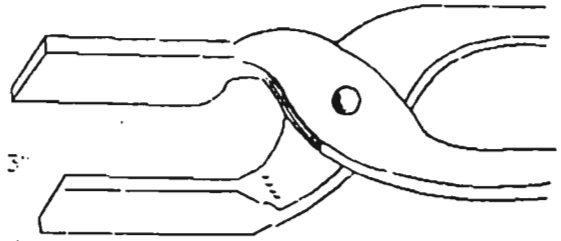

Next you'll need a tool to form the "V" notch. I made one from a large dimension railroad spike. I upset the sharp end a little leaving some of the taper and the end about 1/4" wide. Then I split the end over a sharp edge of the anvil to form a 90 degree "V".

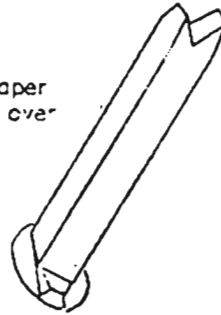

Let the end of the spike flare out as you form the "V".

Use the new tool to crimp the flat jaw of the tong over a sharp edge of the anvil or some other convenient sharp edge.

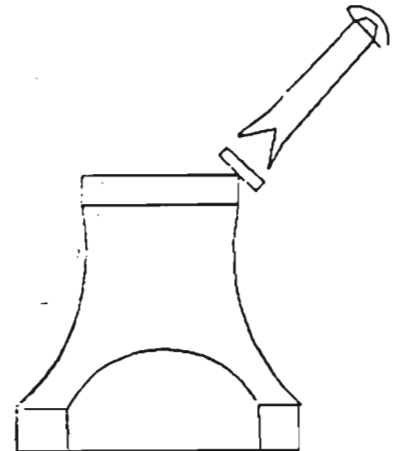

Crimp the very tip of each flat jaw then on one jaw only move down toward the boss and crimp again leaving approximately 3/4" of the jaw uncrimped between the crimped places.

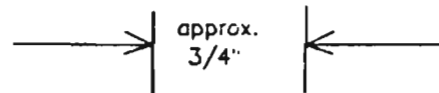

Work the remaining portion of the jaws into a large open loop such that the single "V" notch jaw contacts a point between the double notch jaw. I worked the double jaw over a round rod placed between the two notches to give more clearance from the object being held.

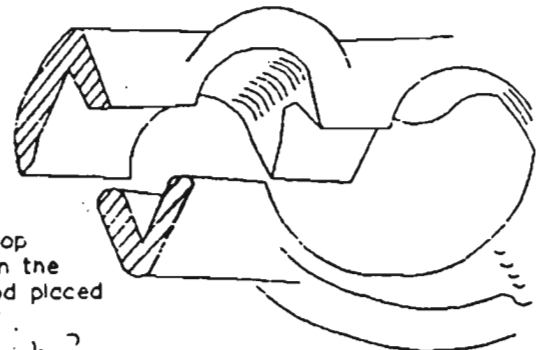

Bill Miller

from: 'The Clinker Breaker' Florida Artist-Blacksmith Assoc. Nov. 1988

BANDSAW CONVERSION

by
Doug Kluender

I recently modified an old vertical Delta woodworker's band saw to use for metal cutting. The key to making this work was finding the proper type of blade and making the saw run slow enough for metal cutting. I use a 14 tooth per inch BI-METAL blade obtained from a local industrial supplier for general purpose metal cutting. This is a good all around blade for mild steel ranging from about 14 gauge to 1/4 inch in thickness. Increase the number of teeth per inch to 16 or 18 if you are using it primarily for lighter gauge stock. Conversely, decrease the number of tpi to 10 to 12 if you regularly use the saw for heavier material. Making the saw run at the appropriate speed was a bit more complicated.

Cutting speeds are typically specified in feet per minute (fpm) of blade travel. To simplify the calculations, I converted the blade speed from fpm to revolutions per minute (rpm) for my saw. The desired cutting speed for mild steel is 330 fpm. Since my saw has a 14" drive wheel, it travels (14 X 3.14)

or 43.96 inches per revolution. To keep it simple I rounded this to 44 inches per revolution. The cutting speed of 330 fpm works out to be (330 X 12) or 3960 inches per minute. Divide this by the drive wheel circumference to obtain the required drive wheel speed in rpm.

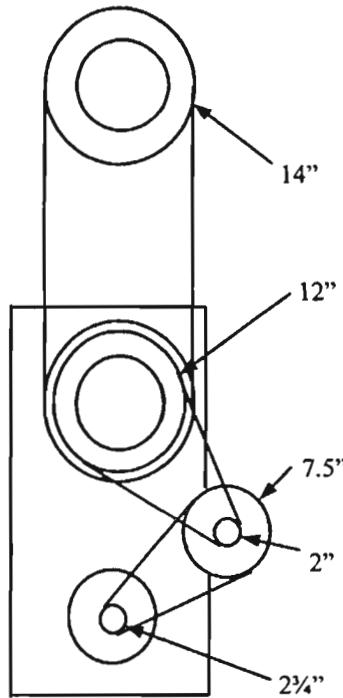

Fig1

In this case, 3960/44 yields a drive wheel speed of 90 rpm. Now the problem is how to gear down the

typical 1725 rpm motor to this speed. In this case it would take a 19.1 to 1 ratio (1725/90 = 1). Using a 2" pulley on the motor would require a 38" pulley on the drive wheel, or a combination of appropriately sized pulleys, belts and/or chains and sprockets. I chose to use belts and pulleys for reasons of availability, versatility, convenience, and cost.

My particular saw is a floor model so I was able to attach an intermediate shaft to the frame using pillow block bearings. This made it possible to achieve the desired speed reduction using an assortment of belts and pulleys. In addition to the relatively low cost, this setup also allows me to change one belt and still use the saw for wood work. With other blade, belt and pulley combinations, it can easily be set up for other materials such as bronze and aluminum. This particular saw also has roller bearing blade guides and a tilting table and fence. These features make it very versatile and capable of making compound miter cuts. I use a wax stick lubricant when cutting metal. This seems to help make the blade last.

Listed below is a general guide to cutting speeds and blade configurations which were derived from the Welder's Handbook.

Material	Speed (fpm)	Blade (teeth per inch)	Blade width
Titanium	45	18	1/2"
Bronze	80	12	1/2"
Chrome Moly	270	14	1/2"
Carbon Steel	330	14	1/2"
Aluminum	1600	9	1/4 to 1/2"
Wood	2700	6	1/4 to 1/2"

Reprinted from California Blacksmith, Vol.22, No.1, Jan./Feb. 1998

Dorothy Steigler's Double Reverse Twist

From notes of Matt Wills, editor of the Great Plains Blacksmith Association

*as demonstrated at the
Rocky Mountain Smiths Conference, Carbondale, Colorado*

One of the best things about attending conferences would have to be having the opportunity to learn from some of the best smiths in the country. Dorothy Steigler would definitely be in that category. Dorothy is a past president of ABANA and is a talented artist. She currently works out of the studio of Stephen Worley in Sand City, California. She trained with Frank Turley in her first years as a smith. Frank commented once that a sign of a good smith would be to produce a twist within twist going in opposite directions. After considerable time working out the details, here is what she presented at the conference.

1. Start by making a simple bundle of four pieces of $\frac{1}{4}$ " round about 8" long. Arc weld the ends and forge weld the bundle for $1\frac{1}{2}$ " on each end (Figure 1). Dorothy has a step-by-step procedure she uses to forge weld. She uses 20 Mule Team Borax as a flux.
 - A. Heat the bundle to an orange heat. Bring out of the fire, brush and flux moderately.
 - B. Return the metal to the fire; use an open fire and keep the metal covered with coke. Find a place to view the metal through the coke, and watch for the flux to begin to dance around on the metal. Turn the bundle to get an even heat. She said to ignore the sparks produced by the 6011 welding rod on the end of the bundle. **Only when the flux is dancing rapidly around are you ready to weld!** Pull the metal from the fire, and give it a forceful sling toward the ground to throw off excess flux and contaminants. Place it on the anvil and using medium blows, tack the rods together. Reflux the metal and return to the fire. When the flux dances again, sling as before and this time hammer more forcefully to a round cross section as you rotate the bundle on the anvil. You will hear the sound change as the metal welds together. She said she always takes two heats to weld. In this way the client won't find a marginal weld.
2. After the bundle is welded, heat very evenly to an orange heat; twist clockwise $2\frac{1}{2}$ times. Make sure the twist is even. If any spots are too loose, use a torch to add heat to the loose areas and tighten evenly. (Figure 1).
3. **Important:** After you have an even twist, reheat the bundle and twist counter clockwise an eighth of a turn to make it open up slightly. Put the small bundle aside to cool.

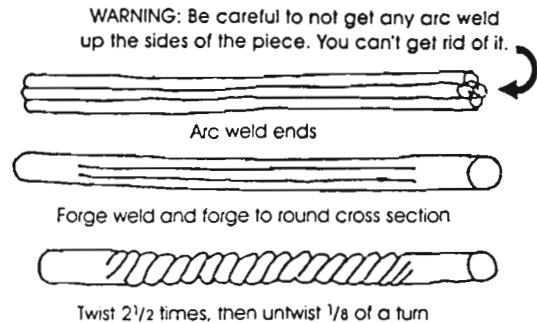

Figure 1.

4. Using the bottom and top dies shown in Figure 2, make the eight pieces for the outside of the twist. Use about $10\frac{1}{2}$ " of $\frac{1}{4}$ " round. Space it evenly and clamp on both sides in the V-grooves. The clamps should be set to the same pressure to keep the piece even on both ends. Drive the top die down on top of the work to form the half-round section with about $1\frac{1}{2}$ " straight on each end. This process is done cold (Figures 3 & 4).

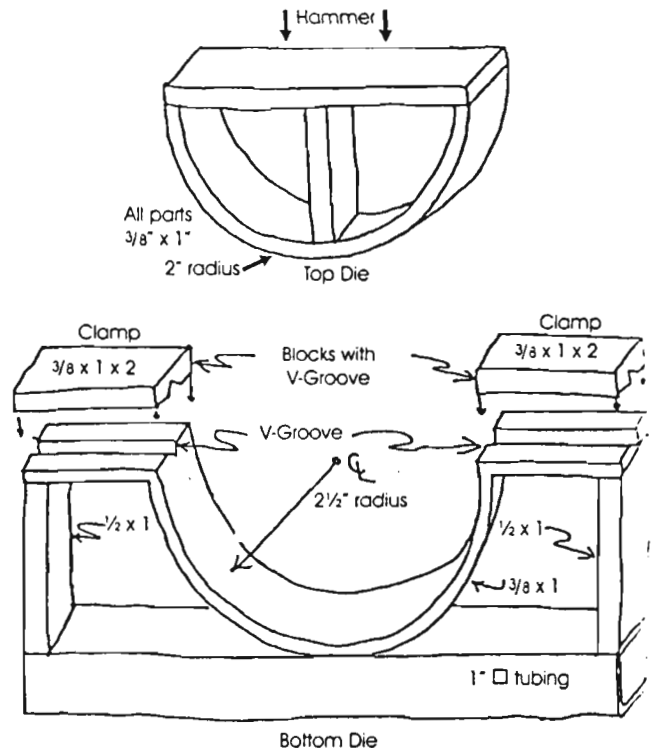

Figure 2.

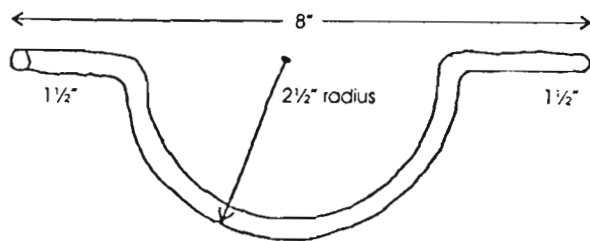

Figure 3. Part produced by top and bottom die.
Since I am a poor artist, it will be similar to Figure 3.

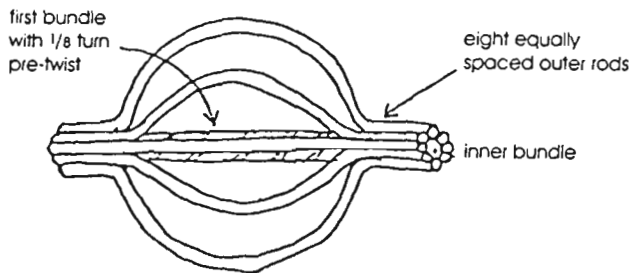

Figure 4. Bundle ready for final twist. Not all rods are shown.

5. Using an arc welder, tack the first two pieces on opposite sides of the inner bundle. Continue adding pieces until you have all eight pieces equally spaced around the inner twist and tack welded on both ends.
6. Forge weld the ends of the entire bundle together on each end using the above welding procedure. The bundle will collect a lot of coke inside. Just ignore it. Have plenty of coke in your fire before you start this weld.
7. After the ends are forge welded, heat the inner and outer bundles to an even heat and twist counterclockwise a quarter of a turn. This will be enough to open the inner twist more so and put the correct twist on the outside rods.
8. There you have it – a twist one way in the middle and the opposite way on the outside. Now you can scarf the ends and forge weld to a shaft for a fireplace tool or other tool.

Thanks to Dorothy Steigler for the great demo at the conference. If you ever get the chance to learn from Dorothy, don't miss it.

CBA Editor's Note: Dorothy was pleased with the article and added the warning note in Figure 1. ♣

ORNAMENTAL SCREW HEADS

(By Rolando DeLeon, Reprinted from "The Anvil's Ring", Vol. 7, Nr. 1, March 1979)

With the use of a few small files; rounds, triangles, etc., some very interesting effects can be achieved with the standard hex head lag screw. The use of files does not damage or distort the hex shape of the heads, so the use of a socket wrench to drive screws in is still possible. Zinc coated lags should be place in muriatic acid to remove the zinc coating. As with most chemicals, care should be taken.

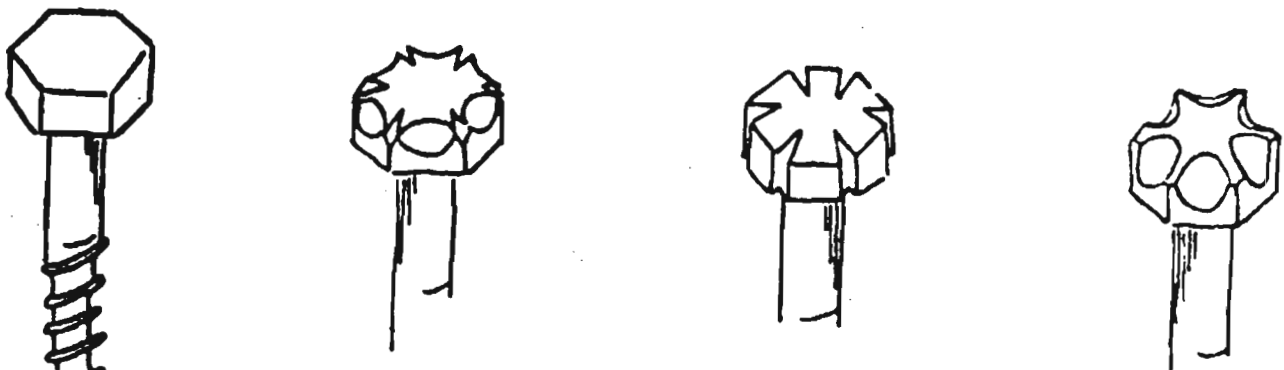

After filing and acid treatment, run lags through forge fire or torch to achieve oxide scale, and wax while still hot. You will be surprised at this quick and easy way of obtaining a "worked" look to the standard wood lag screws. Try on other different types of screws, wood or metal, and bolts as well.

Step-by-step Procedure for Building the Old Miner's Candle Holder

Drawn by Bill Curry

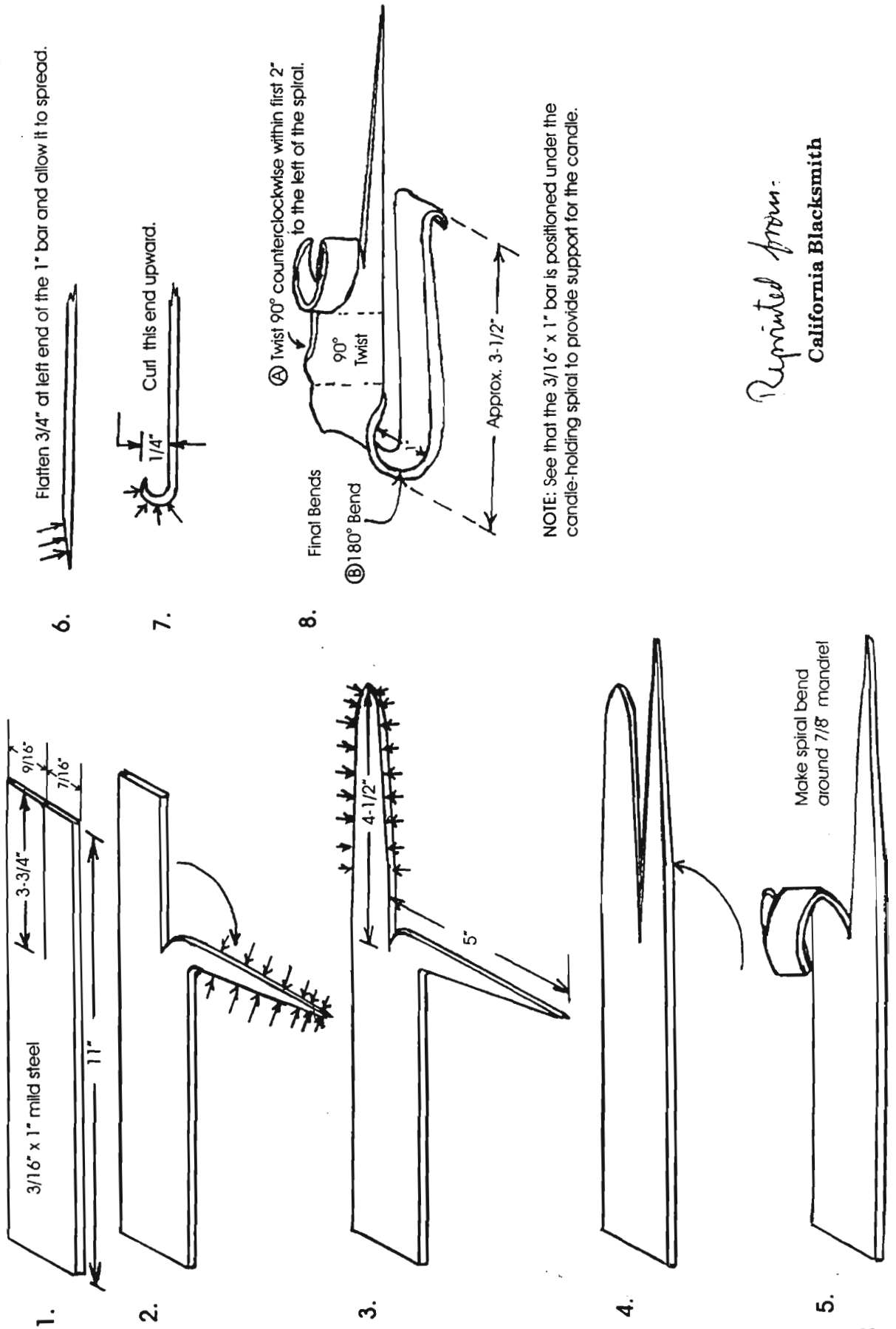

Reprinted from:
California Blacksmith

New Jersey Blacksmiths Association

Blacksmithing Websites

Mary Denise Smith

As computers get cheaper and online prices stabilize, more and more blacksmiths are exploring the World Wide Web. The following is a list of sites that I have compiled from several sources. I have not tested all the addresses, nor so I offer any comments on the contents. Please pass along other sites, corrections to this list, or best of all, comments on web site contents! In the next issue, I will offer websites that have things of interest to blacksmiths, but are not smithing sites, per se. Do you know of any? Tell me! mdsdmb@aol.com

Virtual Junkyard

<http://www.seanet.com/~neilwin/>

Forge & Anvil

<http://www.gactr.uga.edu/forge/>

Elektric Anvil

<http://www.mcs.net/~frnklyn/elektric/anvil.html>

Blacksmith's Journal

<http://www.usmo.com/~journal/index.html>

Blacksmith's Gazette

<http://www.services.skagit.com/blacksmith>

Anvil Magazine

<http://www.anvilmag.com/>

Metal Working News Group

<http://www.drn.zippo.com/news-bin/>

Artmetal

<http://www.artmetal.com>

Alabama Forge Council

<http://www.the-matrix.com/afc/index.html>

Artistic Iron

<http://www.artisticiron.com/>

Atmospheric Gas Forge

<http://www.nets.com/bsmithplaza/mrocks>

Gas Pipe Forge Plans

<http://www.flash.net/~dwwilson/forge/fgpl.html>

Booker T Washington Metal Sculpture CLass

<http://www.flash.net/~dwwilson/btw/btw.html>

Mingly's Using Iron

<http://www.pacific.net.sg/~mingly/mnglyfaq.htm>

National Welder's Supply

<http://www.nationalwelders.com/surplus/lincoln.html>

Welding Institute

<http://www.twi.co.uk/bestprac/jobknol/jobknol.html>

Sybersteel

<http://www.sybersteel.com/websearch/index.shtml>

Welding Canada Magazine

<http://www.mhbizlink.com/welding>

Welders World Mailorder

<http://www.welders.com/>

Metal Web News

<http://www.mindspring.com/~wgray1>

Weather Vanes

<http://www.denninger.com>

Heritage Farmstead Museum

<http://www.io.com/~tam/heritagefarm.home.html>

Alan Rodgers Iron Works

<http://members.aol.com/Forgeanvil/forgeanvil.html>

Skipjack Press

<http://www.bookmasters.com/skipjack/>

Society of American Silversmiths

<http://www.silversmithing.com/>

Crucible Materials Corporation

<http://www.crucibleservice.com/>

Celtic Knot Forge

<http://www.net/~frnklyn/homepage/>

A.P. Green Industries

<http://www.apgreen.com/index.htm>

Sahinler Air Hammers

<http://www.powerhammers.com/>

Lincoln Electric

<http://www.lincolnelectric.com/>

Miller Electric

<http://www.millerwelds.com/>

Johnny Stout Custom Knives

<http://www.concentric.net/jlstout/index.html>

Valentine Armouries

<http://www.varmouries.com/>

American Bladesmith Society

<http://www.web2.com/abs/>

Material Safety Data Sheets

[gopher://atlas.chem.utah.edu/11/MSDS](http://atlas.chem.utah.edu/11/MSDS)

Texas Artist Blacksmith Association

<http://www.tex-bilt.com/taaba.html>

Linden Blacksmithing Books

<http://www.lindenpub.com/title2.htm>

Powells Technical Books

<http://www.powells.com>

Reprinted from: *Forge Facts*, a Publication of the Rocky Mountain Smiths

How to Join or Renew your Membership in NJBA:

NJBA dues are \$15 per year. Please make out your check to
"New Jersey Blacksmiths Association."

Please mail checks to

NJBA, 222 Laurel Place, Neptune, NJ,

along with the information requested below. You will receive the most recent newsletter as an acknowledgment of your membership. Annual dues are due on June 1. If you join in April through June, you will not owe renewal dues until June of the following year. If you join at another time of year, you will owe dues the following June.

(The following information will be listed in a roster available to other members.)

Name _____ Home Phone _____ Day Phone _____

Address, City, State, Zip _____

Electronic Mail Address _____

New Jersey Blacksmiths Association

NEWSLETTER

222 Laurel Place
Neptune, NJ 07753

